



CHE654 – Plant Design Project #1 Semester 1, 2023



DESIGN OF A STYRENE PRODUCTION PROCESS

(Courtesy of the Department of Chemical Engineering at West Virginia University)

Introduction

Styrene, also known as vinyl benzene, is an organic compound with the chemical formula $C_6H_5CH=CH_2$. This cyclic hydrocarbon is a colorless oily liquid that evaporates easily and has a sweet smell, although high concentrations confer a less pleasant odor. Styrene is the precursor to polystyrene and several copolymers. Approximately 15 billion pounds are produced annually.

We plan to evaluate the economics for a process to manufacture styrene by dehydrogenating ethyl benzene. Figure 1 is a preliminary process flow diagram (PFD) for the styrene production process. You should use this as a starting point. However, any change that you can justify that does not violate the laws of nature is allowed. Your job is to analyze the simplified styrene production process, to suggest profitable operating conditions, and to write a final report summarizing your findings. Note that optimization is NOT required in this design project.

Process Description

Figure 1 is a preliminary process flow diagram (PFD) for the styrene production process. In this process, styrene is manufactured by the dehydrogenation of ethyl benzene in Unit 500. The reaction is endothermic, reversible, and limited by equilibrium. Reaction occurs at high temperature (800 - 950 K) and low pressure (0.4 - 1.4 bar) in order to shift the equilibrium to the right to favor styrene production. The raw material is ethyl benzene, which is preheated in E-501 to a saturated vapor. This is then mixed with steam (produced from the fired heater H-501) to provide the heat of reaction and to serve as an inert diluent to help shift the reaction to the right. The steam to ethyl benzene ratio entering R-501 in Stream 6 ranges between 6 and 12. Steam also tends to limit side reactions and helps to extend catalyst life by reducing coke formation on the catalyst. In reactor R-501 the process uses a proprietary iron catalyst that minimizes (but does not eliminate) side reactions at higher temperatures. For simplicity, assume that the only side reaction that occurs in R-501 is the hydrogenation of ethyl benzene to form toluene and methane.

The primary reaction is equilibrium limited and is assumed to approach 80% of equilibrium. The selectivity of the toluene side reaction is a function of reactor temperature. The reactor effluent, Stream 7, is cooled in E-502 to produce steam and then enters a three-phase separator (V-501). The bottom phase of V-501 is waste water stream (Stream 11), which must be decanted and sent for further processing before discharge. Stream 9 leaves the top of the separator and contains all the light gases (methane and hydrogen) and can be used as a fuel gas. Stream 10 contains most of the toluene, ethyl benzene, and styrene. Stream 10 flows through a pressure reducing valve and then enters a distillation train (T-501 and T-502) where most of the toluene is removed at the top

of first column (T-501) in Stream 17. The remaining toluene and all the ethyl benzene and styrene leaving the bottom of this column in Stream 15 enter the second column (T-502). From T-502, Stream 20 is recycled and mixed with fresh ethyl benzene before the reactor. The bottom product of T-502 leaving in Stream 18 contains the styrene leaving Unit 500.

Process Details

Feed Streams

Stream 1: fresh ethyl benzene, assume available as a liquid at 30°C.

Stream 4: low-pressure process steam available from elsewhere in the plant, to be superheated and used as diluent and heat source for mixture entering reactor in Stream 6.

H-501	E-501	R-501	E-502	P-501A/B	V-501	T-501	E-503	E-504	V-502	T-502	E-505	E-506	V-503	P-502 A/B	P-503 A/B
steam	feed	styrene	product	waste	three-	toluene	condenser	reboiler	reflux	styrene	condenser	reboiler	reflux	styrene	toluene
heater	preheater	reactor	cooler	water	phase	column			drum	column			drum	pump	pump
				pump	separator										

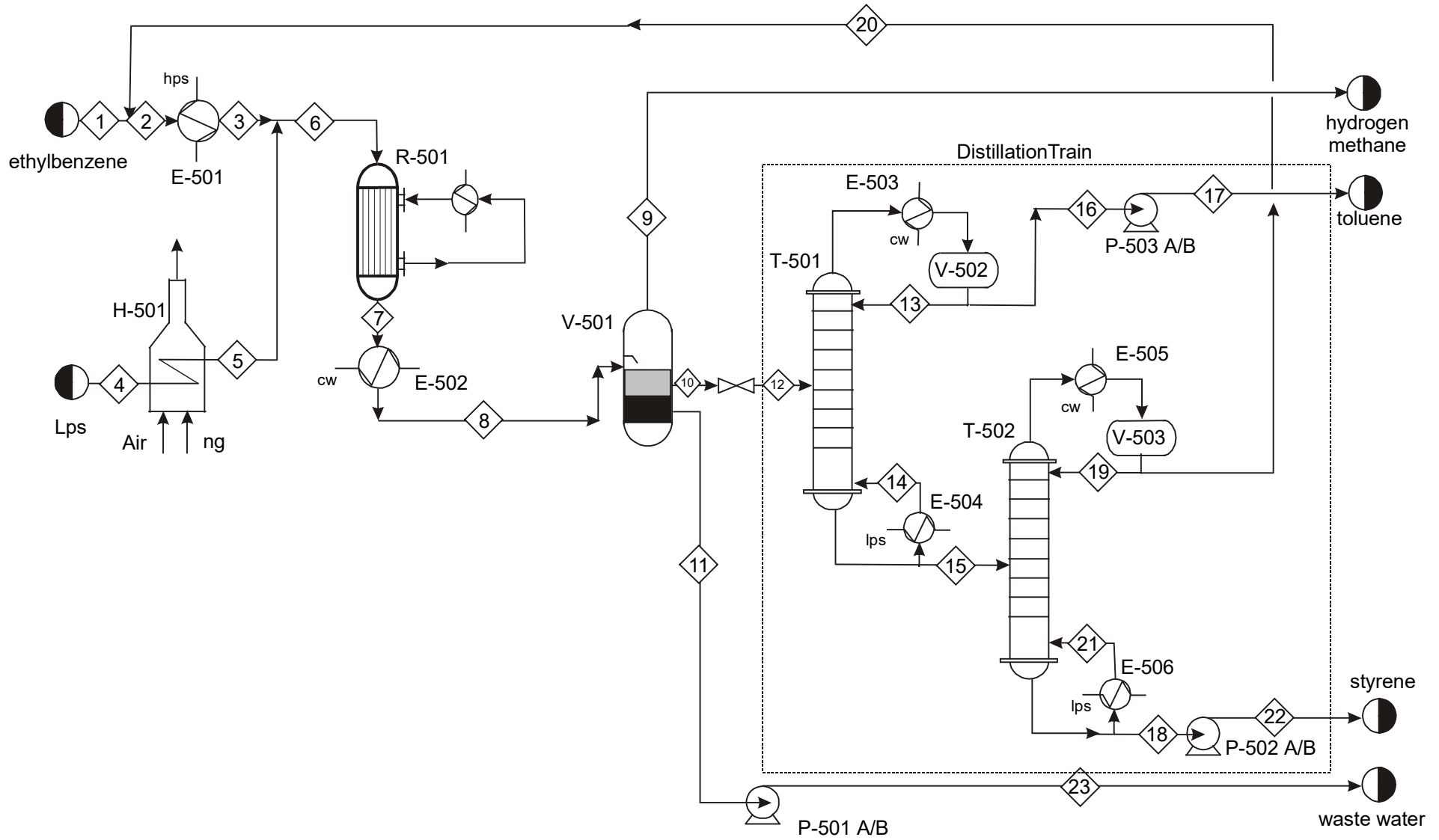

Unit 500: Production of Styrene from Ethylbenzene

Effluent Streams

- Stream 9: light-gas stream of hydrogen and methane with traces of water vapor and small amounts of ethyl benzene and toluene. Take credit as a fuel gas for hydrogen and methane in this stream only.
- Stream 17: 99.5% pure toluene with small amounts of ethyl benzene and styrene. The toluene in Stream 17 is at least 95% of the toluene produced. This stream can be sold as byproduct, but it should not exceed 2% of styrene production.
- Stream 22: styrene crude product of at least 99.5 wt% purity, 100,000 metric tons/yr, with small amounts of ethyl benzene. The styrene in Stream 22 is at least 98% of the styrene entering the distillation train.
- Stream 23: waste water stream from V-501; assume to be pure water for this design project, but Stream 11 must be processed at the associated waste-water treatment cost.

Recycle Stream.

- Stream 20: primarily ethyl benzene with some toluene and styrene; assume this stream leaves the top of T-501 as a saturated liquid at 60 kPa.

Equipment

Isothermal Fixed-Bed Catalytic Reactor (R-501)

The following reactions occur:

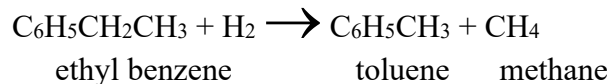
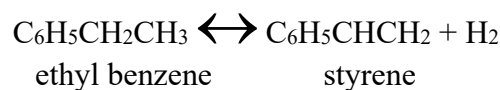

The primary reaction for styrene production is equilibrium limited, and is assumed to run at 80% of equilibrium. The styrene equilibrium conversion is calculated according to the following gas-phase reaction equation:

$$K_{eq} = \frac{y_S y_{H_2} P}{y_{EB}}$$

where y_S , y_{H_2} , and y_{EB} are mole fractions of styrene, hydrogen, and ethyl benzene, respectively, and P is the reactor total pressure in bar (1 bar = 100 kPa). The reaction equilibrium constant is a nonlinear function of temperature (in K) only, and is given as:

$$\ln K_{eq} = 15.5408 - \frac{14852.6}{T}$$

The side reaction is not equilibrium limited, but the fractional selectivity (S) for toluene formation in R-501 is temperature dependent and is given by the following:

$$S = S_0 T^n$$

where S_0 and n must be obtained by regression of data provided below by the company lab. These data should not be extrapolated outside the range 800 – 950 K. The catalyst cost is significant. Based on the anticipated reactor size for this unit, assume catalyst use is at 40 metric ton/year for a 100,000 metric ton/yr styrene facility, with catalyst replacement required every 21 months.

Three-Phase Separator (V-501)

For purposes of this design project, assume the methane and hydrogen are insoluble in Streams 10 and 11, and the water is immiscible in the organic phase in Stream 10. Trace amounts of water vapor may be present in the methane/hydrogen gas in Stream 9. However, after decanting pure liquid water from V-501 in Stream 11, the styrene, ethyl benzene, and toluene are partitioned between Streams 9 and 10 according to Raoult's Law. You should optimize V-501 (using vapor-liquid equilibrium equations developed in class) for the best temperature and pressure to operate this unit in order to maximize the recovery of crude styrene in Stream 10. Although Stream 11 contains trace amounts of waste components, assume it has the properties of pure water but with the treatment costs associated with waste water. To minimize polymerization of the styrene product, this flash unit should be designed to operate between 0.5 and 1.5 bar and between 50 and 100°C.

Distillation Columns (T-501 and T-502)

From the separator, the organic liquid product stream (Stream 12) enters the distillation section of Unit 500. The columns operate at (or below) the normal boiling point of styrene at the desired column outlet pressure. To eliminate significant polymerization of styrene, the distillation units are operated at a moderate vacuum to keep the temperature low. The top product from T-501 (Stream 16) must contain at least 95% of the toluene entering the distillation train at a purity of 99.5%, with the rest of Stream 16 being ethyl benzene. This stream is pumped to another unit that makes toluene available for external sale at market prices. This unit is not considered in this design project.

The bottoms product from the toluene column (T-501) is further distilled in the ethyl benzene recycle column (T-502). The overhead ethyl benzene product, Stream 20, contains small amounts of toluene and styrene and is recycled to mix with Stream 1 before the reactor. The bottoms product of T-502 must be at least 99.5% pure styrene with at least 98% recovery of the styrene entering the distillation train, and the remainder is ethyl benzene.

For information only, inhibitors must be added (about 10-50 ppm) to reduce polymerization, but this will not be considered in this design. Also, further preparation of styrene for sale is done in another unit. These processes are not considered in this design project.

Design of Heat Exchangers, E-501 and E-502

A detailed design of E-501 and E-502 is required for base-case conditions. It should be assumed that cooling water is available at the conditions specified in the Appendix of this problem statement. For this heat exchanger design, the following information should be provided:

- Diameter of shell
- Number of tube and shell passes
- Number of tubes per pass
- Tube pitch and arrangement (triangular/square/..)
- Number of shell-side baffles, if any, and their arrangement (spacing, pitch, type)
- Diameter, tube-wall thickness, shell-wall thickness, and length of tubes
- Calculation of both shell- and tube-side film heat transfer coefficients
- Calculation of overall heat transfer coefficient (you may assume that there is no fouling on either side of the exchanger)
- Heat transfer area of the exchanger
- Shell-side and tube-side pressure drops (calculated, not estimated)
- Materials of construction
- Approximate cost of the exchanger

A detailed sketch of the two exchangers should be included along with a set of comprehensive calculations in an appendix for the design of the heat exchangers. You should use ASPEN Exchanger Design & Rating (EDR) in the ASPEN Plus simulator to carry out the detailed design.

Other Equipment Considerations

Two streams that are to be mixed are required to be at identical pressures. Pressure reduction is accomplished by adding a reducing valve. For this design, it is assumed that valves are available as needed at no cost. Flow must occur from a higher pressure to a lower pressure. Pumps increase the pressure of liquid streams, and compressors are used to increase the pressure of gaseous streams. For example, locations where pumps are needed are in the liquid streams exiting V-501, T-501, and T-502, and to remove material from any towers operating under vacuum conditions. For this project, assume that pumps and compressors are available as needed at no cost and that there is no cost associated with any pressure increases. However, based on your design, the report should indicate placement of pumps, compressors and valves on the PFD.

Data

Some data needed to do this project are provided below. Additional property data are available in references [1] and [2].

Fractional Selectivity Data for Toluene

Temperature (K)	800	850	900	950
Fractional Selectivity (S)	0.01	0.03	0.06	0.13

Typical Costs and Selling Prices

Steam/Fuel (cost or credit)

Low-pressure steam (446 kPa, saturated)	\$5.00/1000 kg
Medium-pressure steam (1135 kPa, saturated)	\$7.31/1000 kg
High-pressure steam (4237 kPa, saturated)	\$8.65/1000 kg

Natural gas or fuel gas (446 kPa, 25EC)	\$3.00/GJ
Electricity	\$0.05/kWh
Boiler feed water (at 549 kPa, 90EC)	\$2.54/1000 kg

Cooling Water

\$0.16/GJ

available at 516 kPa and 30EC

return pressure 308 kPa

return temperature should be no more than 15EC above the inlet temperature

Refrigerated Water

\$1.60/GJ

available at 516 kPa and 10EC

return pressure 308 kPa

return temperature can be no more than 20EC

Process Water

\$0.04/1000kg

available at 300 kPa and 25EC

Waste Water Treatment

\$5/1000 kg

Recent Chemical Prices (Check current prices in the *Chemical Market Reporter*)

Component	Price, \$/kg
Ethyl benzene	0.55
Styrene	0.682
Toluene	0.484

Other Data

Annual operating hours	8000 (330 days)
Catalyst Cost	\$1/kg
Catalyst Load	40 metric ton
Catalyst Replacement	21 months

Economic Analysis

When evaluating alternative cases, you should carry out an economic evaluation and profitability analysis based on a number of economic criteria such as payback period, internal rate of return, and cash flow analysis. In addition, the following objective function should be used. It is the equivalent annual operating cost (EAOC), and is defined as

$$\text{EAOC} = -(\text{product value} - \text{feed cost} - \text{other operating costs} - \text{capital cost annuity})$$

A negative value of EAOC means there is a profit. It is desirable to minimize EAOC; *i.e.*, a large negative value of EAOC is very desirable.

Utility costs are those for steam, cooling water, boiler-feed water, natural gas, and electricity.

The capital cost annuity is an **annual** cost (like a car payment) associated with the **one-time**, fixed capital cost of plant construction and installation. A list of fixed capital costs on an installed basis (“installed cost”) for all pieces of equipment will be provided by mid-March.

The capital cost annuity is defined as follows:

$$\text{capital cost annuity} = FCI \frac{i(1+i)^n}{(1+i)^n - 1} \quad (12)$$

where *FCI* is the installed cost of all equipment; *i* is the interest rate; and *n* is the plant life, in [y]. For accounting purposes, take *i* = 0.15 and *n* = 10.

For detailed sizing, costing, and economic evaluation including profitability analysis, you may use the Aspen Process Economic Analyzer (formerly Aspen Icarus Process Evaluator) in Aspen Plus. However, it is also a good idea to independently verify the final numbers based on other sources such as cost data given below.

Other Information

You should assume that a year equals 8,000 hours. This is about 330 days, which allows for periodic shut-down and maintenance.

Final Comments

As with any open-ended problem; *i.e.*, a problem with no single correct answer, the problem statement above is deliberately vague. You may need to fill in some missing data by doing a literature search, Internet search, or making assumptions. The possibility exists that as you work on this problem, your questions will require revisions and/or clarifications of the problem statement. You should be aware that these revisions/clarifications may be forthcoming.

Moreover, in some areas (e.g. sizing/costing) you are given more data and information than what is needed. You must exercise engineering judgment and decide what data to use. Also you should also seek additional data from the literature or Internet to verify some of the data, e.g. the prices of products and raw materials.

Appendix 1 Economic Data

Cost Data

Raw Materials

Ethyl benzene *see Chemical Market Reporter*

Product

Styrene *see Chemical Market Reporter*

Utility Costs

Low Pressure Steam (618 kPa saturated) \$6.62/1000 kg

Medium Pressure Steam (1135 kPa saturated) \$7.31/1000 kg

High Pressure Steam (4237 kPa saturated) \$8.65/1000 kg

Natural Gas (446 kPa, 25°C) \$3.00/GJ

Fuel Gas \$2.75/GJ

use this price for fuel gas credit

Electricity \$0.06/kW h

Boiler Feed Water (at 549 kPa, 90°C) \$2.54/1000 kg

Cooling Water \$0.16/GJ

available at 516 kPa and 30°C

return pressure \geq 308 kPa

return temperature is no more than 15°C above the inlet temperature

Refrigerated Water \$1.60/GJ

available at 516 kPa and 10°C

return pressure \geq 308 kPa

return temperature is no higher than 20°C

Deionized Water \$1.00/1000 kg

available at 5 bar and 30°C

Wastewater Treatment \$50/1000 m³

Equipment Costs (Purchased)

Piping	$\$/m = 5.0$ (diameter, in)
Valves	$\$100$ (flow diameter, in) ^{0.8} for control valve with orifice plate, double the price
Pumps	$\$630$ (power, kW) ^{0.4}
Heat Exchangers	$\$1030$ (area, m ²) ^{0.6} add 25% additional for boilers or evaporators
Compressors	$\$770$ (power, kW) ^{0.96} + $\$400$ (power, kW) ^{0.6} assume 70% efficiency
Turbine	$\$2.18 \times 10^5$ (power output, MW) ^{0.6} assume 65% efficiency
Fired Heater	$\$635$ (duty, kW) ^{0.8} assume 80% thermal efficiency assume can be designed to use any organic compound as a fuel
Vessels	$\$[1.67(0.959 + 0.041P - 8.3 \times 10^{-6}P^2)] \times 10^z$ $z = (3.17 + 0.2D + 0.5 \log_{10}L + 0.21 \log_{10}L^2)$ $D =$ diameter, m $0.3 \text{ m} < D < 4.0 \text{ m}$ $L =$ height, m $3 < L/D < 20$ $P =$ absolute pressure, bar
Reactor	assume to be \$1 million
Separator	if added to feed section – \$50,000 per separator

Equipment Cost Factors

Pressure Factors

Pressure (absolute)	< 10 atm, 0.0	does not apply to turbines, compressors, vessels, packing, trays, or catalyst, since their cost equations include pressure effects
	10 - 20 atm, 0.6	
	20 - 40 atm, 3.0	
	40 - 50 atm, 5.0	
	50 - 100 atm, 10	

Material Factors

Carbon Steel	0.0
Stainless Steel	4.0

Total Installed Cost = Purchased Cost (4 + material factor + pressure factor)

Heat Exchangers

For heat exchangers that do not have to be designed in detail, use the following approximations for heat transfer coefficients to allow you to determine the heat transfer area and heat exchanger cost.

situation	h (W/m ² °C)
condensing steam	6000
condensing organic	1000
boiling water	7500
boiling organic	1000
flowing liquid	600
flowing gas	60

References

1. Felder, R. M. and R. W. Rousseau, *Elementary Principles of Chemical Processes (3rd ed.)*, Wiley, New York, 2000.
2. Perry, R. H. and D. Green, eds., *Perry's Chemical Engineering Handbook (7th ed.)*, McGraw-Hill, New York, 1997.