



CHE654 – Plant Design Project #2
Semester 1, 2023



DESIGN OF AN EHTYL BENZENE PRODUCTION PROCESS

(Courtesy of the Department of Chemical Engineering at West Virginia University)

Introduction

Ethyl benzene (EB) is used as a chemical intermediate in making styrene, the building block for manufacturing polystyrene. It is a major commodity chemical that is produced throughout the world. A byproduct of the process is diethyl benzene (DEB) that is an intermediate in divinyl benzene manufacture. Since the demand for styrene is far greater than the demand for divinyl benzene, the selectivity for our process should favor ethyl benzene production.

Ethyl benzene is produced by coupling ethylene and benzene with an acidic catalyst. Diethyl benzene forms when ethylene reacts with ethyl benzene. The formation of multiply-substituted benzenes is limited by running the reaction with a large excess of benzene. The reactions that produce EB and DEB are

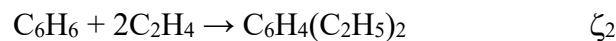
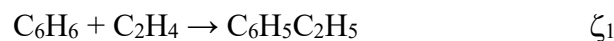

where ζ_i is the extent of reaction. The selectivity of these reactions is determined by the feed ratio and processing conditions.

The purpose of this project is to continue a preliminary analysis to determine the feasibility of constructing a chemical plant to manufacture 100,000 tonne/year of ethylbenzene. The raw materials are benzene and ethylene. Note that optimization is NOT required in this design project.

A suggested process flow diagram (PFD) is shown in Figure 1. You should use this as a starting point. Your primary task is to develop a preliminary design of the ethyl benzene production process and recommend its operating condition that gives a “profitable” equivalent annual operating cost, or EAOC (This term is defined later). Process improvements that increase the EAOC are also desired. Any changes that you can justify, which not violate the laws of nature, are allowed. Your assignment is to develop a “profitable” case (but not necessarily the “best” case), where “profitable” is dependent upon economic considerations, *i.e.*, EAOC. In reporting your best case, clearly indicate the modified process and state the operating conditions for the modified process and the corresponding EAOC. Also, state any recommendations you have for additional process improvements that you were not able to incorporate into the process calculations. Note that optimization is NOT required in this design project.

Chemical Reaction

The production of EB takes place via the direct addition reaction between ethylene and benzene:

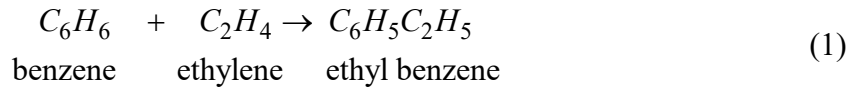

The reaction between ethylbenzene and ethylene to produce di-ethylbenzene also takes place:

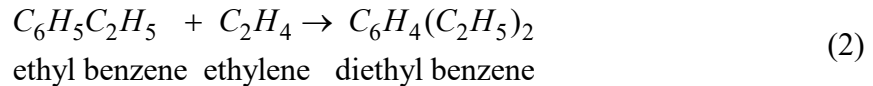

Additional reactions between di-ethylbenzene and ethylene yielding tri- and higher ethyl benzene are also possible. However, in order to minimize these additional reactions, the molar ratio of benzene to ethylene is kept high, at approximately 8:1.

Process Description

Fresh benzene (Stream 1) and ethylene (Stream 2) are combined with a recycle stream containing unreacted benzene and a small amount of ethyl benzene. The combined stream is fed to a reactor where all of the ethylene in the feed reacts. The reactor effluent (Stream 5) is cooled so that most of the benzene, ethyl benzene, and diethyl benzene condenses. An ethane impurity from the ethylene feed as well as some benzene and ethyl benzene vapor are purged from the process and used as fuel gas. The condensed liquid is fed to the first distillation column. A high purity benzene stream is removed from the top of the column and recycled. The bottoms from the first column are sent to a second distillation column. The second column produces high-purity ethyl benzene in the top stream and diethyl benzene in the bottom.

Process Details

Streams and Equipment Details

Stream 1: Benzene – at 25°C and 2000 kPa, assumed pure

Stream 2: Ethylene – at 25°C and 2000 kPa, 95 mol% ethylene, 5 mol% ethane

Stream 3: feeds adjusted based on recycle composition to have 8:1 benzene/ethylene ratio

Stream 4: mixed feed heated to 400°C

Stream 5: 95% conversion of limiting reactant in R-301, the selectivity for ethyl benzene production is a function of benzene-to-ethylene ratio. This relationship is expressed as

$$\frac{\xi_2}{\xi_1} = \left(\frac{E_3}{B_3} \right)^{1.2} \quad (3)$$

where ξ_i is the extent of reaction for the reactions in Equations 1 and 2, and the subscript 3 refers to the molar content of ethylene (E) and benzene (B) of Stream 3. The size of T-301 limits the B_3/E_3 ratio to a maximum value of 12.

Stream 6: vapor/liquid mixture, steam may be produced in E-301, cooling water may also be used. The temperature and pressure of Stream 6 are decision variables

Stream 7: fuel gas purge; credit may be taken for fuel gas based on HHV

Stream 8: mostly benzene, ethylbenzene, and di-ethylbenzene. The sole purpose of V-301 is to allow the vapor and liquid mixture in Stream 6 to separate at the same temperature and pressure as Stream 6

Stream 9: benzene recycle

Stream 10: ethylbenzene/di-ethylbenzene mixture

Stream 11: product ethylbenzene, 2 ppm di-ethylbenzene maximum

Stream 12: di-ethylbenzene to waste treatment

Distillation Column Information

Distillation Column (T-301)

This column runs at 150 kPa. Separation of benzene from ethylbenzene and di-ethylbenzene occurs in this column. Of the benzene in Stream 8, 99.5% enters Stream 9. Similarly, 99.5% of the ethylbenzene and all of the di-ethylbenzene in Stream 8 enters Stream 10.

Heat Exchanger (E-302)

In this heat exchanger, the some of the contents of the stream leaving the bottom of T-301 entering to E-902 are vaporized and returned to the column. The amount returned to the column is equal to the amount in Stream 10. The temperature of these streams is the boiling point of ethylbenzene at the column pressure. The heat required may be estimated by the heat of vaporization of each component at the boiling point of ethylbenzene at column pressure. There is a cost for the amount of steam needed to provide energy to vaporize the stream; this is a utility cost. The steam temperature must always be higher than the temperature of the stream being vaporized.

Heat Exchanger (E-303)

In this heat exchanger, the contents of the top of T-301 are partially condensed from saturated vapor to saturated liquid at the column pressure. You may assume that

benzene and all heavier components condense completely and that any ethylene and ethane present do not condense and are vented from E-903 (not shown) and enter the fuel gas stream. Condensation occurs at the boiling point of each condensing component at the column pressure. There is a cost for the amount of cooling water needed; this is a utility cost. The cooling water leaving E-303 must always be at a lower temperature than that of the stream being condensed. The ratio of Stream 9 to the stream recycled back to T-301 is 1/3.

Distillation Column (T-302)

This column runs at the 150 kPa. Separation of ethylbenzene and di-ethylbenzene occurs in this column. The maximum amount of di-ethylbenzene in Stream 11 is 2 ppm, and 99.95 % of the ethylbenzene in Stream 10 enters Stream 11.

Heat Exchanger (E-304)

In this heat exchanger, the some of the contents of the stream leaving the bottom of T-302 are vaporized and returned to the column. The amount returned to the column is equal to the amount in Stream 12. The temperature of these streams is the boiling point of di-ethylbenzene at the column pressure. The heat required may be estimated by the heat of vaporization of each component at the boiling point of di-ethylbenzene at column pressure. There is a cost for the amount of steam needed to provide energy to vaporize the stream; this is a utility cost. The steam temperature must always be higher than the temperature of the stream being vaporized.

Heat Exchanger (E-305)

In this heat exchanger, the contents of the top of T-302 are condensed from saturated vapor to saturated liquid at the column pressure. Condensation occurs at the boiling point of each condensing component at the column pressure. There is a cost for the amount of cooling water needed; this is a utility cost. The cooling water leaving E-305 must always be at a lower temperature than that of the stream being condensed. The ratio of Stream 11 to the stream recycled back to T-302 is 2/3.

Design of Heat Exchanger, E-301

A detailed design of the heat exchanger E-301 is required for base-case conditions. It should be assumed that cooling water is available at the conditions specified in the Appendix of this problem statement. For this heat exchanger design, the following information should be provided:

- Diameter of shell
- Number of tube and shell passes
- Number of tubes per pass
- Tube pitch and arrangement (triangular/square/..)
- Number of shell-side baffles, if any, and their arrangement (spacing, pitch, type)
- Diameter, tube-wall thickness, shell-wall thickness, and length of tubes
- Calculation of both shell- and tube-side film heat transfer coefficients
- Calculation of overall heat transfer coefficient (you may assume that there is no fouling on either side of the exchanger)

- Heat transfer area of the exchanger
- Shell-side and tube-side pressure drops (calculated, not estimated)
- Materials of construction
- Approximate cost of the exchanger

A detailed sketch of the exchanger should be included along with a set of comprehensive calculations in an appendix for the design of the heat exchanger. You should use ASPEN Exchanger Design & Rating (EDR) in the ASPEN Plus simulator to carry out the detailed design.

H-301	R-301	E-301	V-301	T-301	E-302	E-303	T-302	E-304	E-305
fired	ethylbenzene	reactor	flash	benzene	benzene	benzene	ethylbenzene	ethylbenzene	ethylbenzene
heater	reactor	cooler	drum	tower	tower	tower	condenser	tower	tower
				reboiler	reboiler	condenser		reboiler	condenser

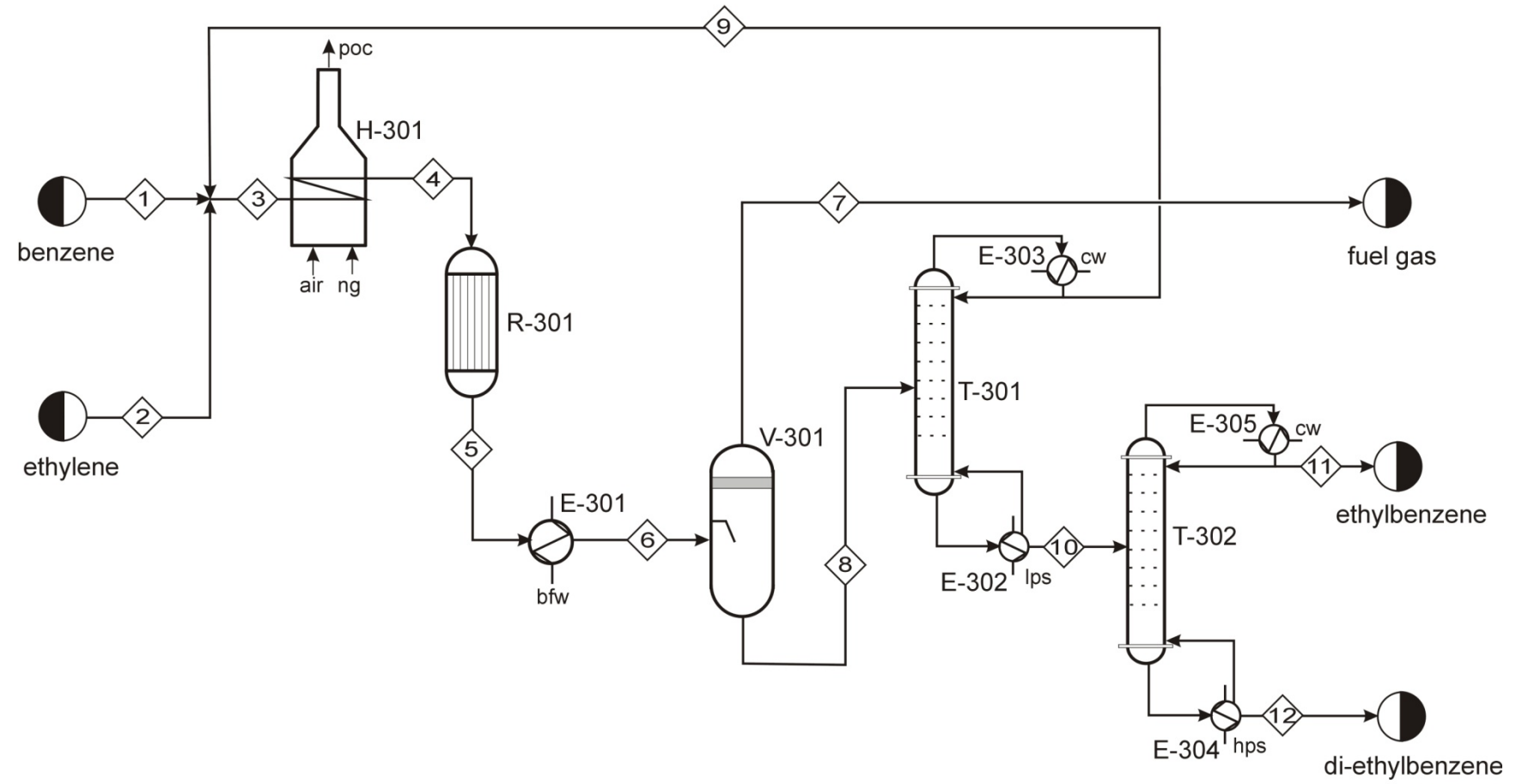

Unit 300: Ethylbenzene Process

Economic Analysis

When evaluating alternative cases, you should carry out an economic evaluation and profitability analysis based on a number of economic criteria such as payback period, internal rate of return, and cash flow analysis. In addition, the following objective function should be used. It is the equivalent annual operating cost (EAOC), and is defined as

$$\text{EAOC} = -(\text{product value} - \text{feed cost} - \text{other operating costs} - \text{capital cost annuity})$$

A negative EAOC means there is a profit. It is desirable to minimize the EAOC; i.e., a large negative EAOC is very desirable, although you are not being asked to carry out optimization.

Utility costs are those for steam, cooling water, boiler-feed water, natural gas, and electricity..

The capital cost annuity is an **annual** cost (like a car payment) associated with the **one-time**, fixed cost of plant construction. The capital cost annuity is defined as follows:

$$\text{capital cost annuity} = FCI \frac{i(1+i)^n}{(1+i)^n - 1}$$

where *FCI* is the installed cost of all equipment; *i* is the interest rate, *i* = 0.15; and *n* is the plant life for accounting purposes, *n* = 10.

For detailed sizing, costing, and economic evaluation including profitability analysis, you may use the Aspen Process Economic Analyzer (formerly Aspen Icarus Process Evaluator) in Aspen Plus Version 7. However, it is also a good idea to independently verify the final numbers based on other sources such as cost data given below.

Other Information

You should assume that a year equals 8000 hours. This is about 330 days, which allows for periodic shut-down and maintenance.

Final Comments

As with any open-ended problem; i.e., a problem with no single correct answer, the problem statement above is deliberately vague. You may need to fill in some missing data by doing a literature search, Internets search, or making assumptions. The possibility exists that as you work on this problem, your questions will require revisions and/or clarifications of the problem statement. You should be aware that these revisions/clarifications may be forthcoming.

Moreover, in some areas (e.g. sizing/costing) you are given more data and information than what is needed. You must exercise engineering judgment and decide what data to use. Also you should also seek additional data from the literature or Internet to verify some of the data, e.g. the prices of products and raw materials.

Appendix 1

Economic Data

Equipment Costs (Purchased)

Note: The numbers following the attribute are the minimum and maximum values for that attribute. For a piece of equipment with a lower attribute value, use the minimum attribute value to compute the cost. For a piece of equipment with a larger attribute value, extrapolation is possible, but inaccurate.

Pumps	$\log_{10}(\text{purchased cost}) = 3.4 + 0.05 \log_{10} W + 0.15 [\log_{10} W]^2$ $W = \text{power (kW, 1, 300)}$ assume 80% efficiency
Heat Exchangers	$\log_{10}(\text{purchased cost}) = 4.6 - 0.8 \log_{10} A + 0.3 [\log_{10} A]^2$ $A = \text{heat exchange area (m}^2\text{, 20, 1000)}$
Compressors	$\log_{10}(\text{purchased cost}) = 2.3 + 1.4 \log_{10} W - 0.1 [\log_{10} W]^2$ $W = \text{power (kW, 450, 3000)}$ assume 70% efficiency
Compressor Drive	$\log_{10}(\text{purchased cost}) = 2.5 + 1.4 \log_{10} W - 0.18 [\log_{10} W]^2$ $W = \text{power (kW, 75, 2600)}$
Turbine	$\log_{10}(\text{purchased cost}) = 2.5 + 1.45 \log_{10} W - 0.17 [\log_{10} W]^2$ $W = \text{power (kW, 100, 4000)}$ assume 65% efficiency
Fired Heater	$\log_{10}(\text{purchased cost}) = 3.0 + 0.66 \log_{10} Q + 0.02 [\log_{10} Q]^2$ $Q = \text{duty (kW, 3000, 100,000)}$ assume 80% thermal efficiency assume can be designed to use any organic compound as a fuel
Vertical Vessel	$\log_{10}(\text{purchased cost}) = 3.5 + 0.45 \log_{10} V + 0.11 [\log_{10} V]^2$ $V = \text{volume of vessel (m}^3\text{, 0.3, 520)}$
Horizontal Vessel	$\log_{10}(\text{purchased cost}) = 3.5 + 0.38 \log_{10} V + 0.09 [\log_{10} V]^2$ $V = \text{volume of vessel (m}^3\text{, 0.1, 628)}$
Catalyst	\$2.25/kg
Packed Tower	Cost as vessel plus cost of packing
Packing	$\log_{10}(\text{purchased cost}) = 3 + 0.97 \log_{10} V + 0.0055 [\log_{10} V]^2$

$V =$ packing volume (m^3 , 0.03, 628)

Tray Tower Cost as vessel plus cost of trays

Trays $\log_{10}(\text{purchased cost}) = 3.3 + 0.46 \log_{10} A + 0.37[\log_{10} A]^2$
 $A =$ tray area (m^2 , 0.07, 12.3)

Storage Tank $\log_{10}(\text{purchased cost}) = 5.0 - 0.5 \log_{10} V + 0.16[\log_{10} V]^2$
 $V =$ volume (m^3 , 90, 30,000)

Reactors For this project, the reactor is considered to be a vessel.

It may be assumed that pipes and valves are included in the equipment cost factors. Location of key valves should be specified on the PFD.

Equipment Cost Factors

Total Installed Cost = Purchased Cost (4 + material factor (MF) + pressure factor (PF))

Pressure < 10 atm, PF = 0.0	does not apply to turbines, compressors, vessels, packing, trays, or catalyst, since their cost equations include pressure effects
(absolute) 10 - 20 atm, PF = 0.6	
20 - 40 atm, PF = 3.0	
40 - 50 atm, PR = 5.0	
50 - 100 atm, PF = 10	

Carbon Steel	MF = 0.0
Stainless Steel	MF = 4.0

Utility Costs

Low Pressure Steam (618 kPa saturated)	\$7.78/GJ
Medium Pressure Steam (1135 kPa saturated)	\$8.22/GJ
High Pressure Steam (4237 kPa saturated)	\$9.83/GJ
Natural Gas (446 kPa, 25°C)	\$6.00/GJ
Fuel Gas Credit	\$5.00/GJ
Electricity	\$0.06/kWh
Boiler Feed Water (at 549 kPa, 90°C)	\$2.45/1000 kg
Cooling Water available at 516 kPa and 30°C return pressure \geq 308 kPa	\$0.354/GJ

return temperature is no more than 15°C above the inlet temperature

Refrigerated Water available at 516 kPa and 10°C return pressure \geq 308 kPa return temperature is no higher than 20°C	\$4.43/GJ
Deionized Water available at 5 bar and 30°C	\$1.00/1000 kg
Waste Treatment of Off-Gas	incinerated - take fuel credit
Refrigeration	\$7.89/GJ
Wastewater Treatment	\$56/1000 m ³

Any fuel gas purge may be assumed to be burned elsewhere in the plant at a credit of \$2.50/GJ. Steam produced cannot be returned to the steam supply system for the appropriate credit. Steam produced in excess of that required in this process is purged with no credit.

Feed and Product Prices

Benzene feed	\$ 1.038 per kg
Ethylene feed	\$ 0.737 per kg
Ethyl benzene	\$ 1.38 per kg

Appendix 2

Other Design Data

Heat Exchangers

For heat exchangers, use the following approximations for heat-transfer coefficients to allow you to determine the heat transfer area:

Situation	h (W/m²°C)
condensing steam	6000
condensing organic	1000
boiling water	7500
boiling organic	1000
flowing liquid	600
flowing gas	60

Appendix 3

Reaction Kinetics

The production of ethyl benzene (EB) takes place via the direct alkylation reaction between ethylene (E) and benzene (B) by acid catalysis:

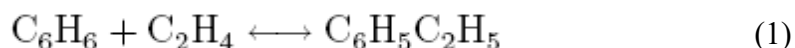

The reaction between EB and ethylene to produce diethyl benzene (DEB) also takes place:

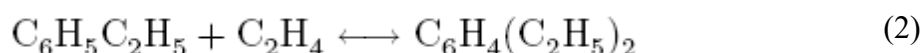

Additional reactions between DEB and ethylene yielding tri- and higher ethyl benzene are also possible. However, in order to minimize these additional reactions, the molar ratio of benzene to ethylene is kept high, at approximately 8:1. The production of diethyl benzene is undesirable, and its value as a side product is low. In addition, even small amounts of DEB in EB cause significant processing problems in the downstream styrene process. Therefore, the maximum amount of DEB in EB is specified as 2 ppm. Excess poly-substituted benzene may be directed towards a waste stream or combusted to reclaim the energy value. In other EB facilities, the early generations of solid acid catalysts were highly corrosive and had a relatively short life, e.g. AlCl_3 , H_3PO_4 on clay, BF_3 on alumina, and others require periodic regeneration. More recently, solid acid catalysts based on zeolites have been demonstrated to have superior properties. Studies in our research division have shown that a β -zeolite catalyst (FX-02) is an active and selective catalyst for the alkylation of benzene with ethylene. FX-02 can be used with polymer-grade ethylene as well as ethylene from fluid catalytic-cracking unit off-gas with concentrations as low as 10-20%. FX-02 also operates at lower temperature and lower pressure than existing catalysts.

The incoming benzene contains a small amount of toluene impurity. The toluene (T) reacts with ethylene to form ethyl benzene and propylene (P):

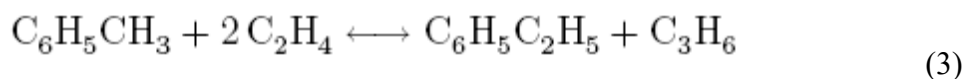

The rate law is based on a Langmuir-Hinshelwood absorption-reaction model, whereby absorbed ethylene reacts with absorbed benzene and ethylbenzene. In addition, absorbed ethylene also reacts with absorbed toluene and ethylbenzene. Reactions described by Equations 1-3 are reversible reactions, where the rate laws correspond to Equations 4-6, respectively.

$$-r_{1B} = \frac{k_1 p_B p_E - k_{-1} p_{EB}}{(1 + K_{BPP} + K_{EPE} + K_{EBPEB} + K_{DEBPDEB} + K_{TPT} + K_{PPP})^2} \quad (4)$$

$$-r_{2EB} = \frac{k_2 p_{EB} p_E - k_{-2} p_{DEB}}{(1 + K_{BPP} + K_{EPE} + K_{EBPEB} + K_{DEBPDEB} + K_{TPT} + K_{PPP})^2} \quad (5)$$

$$-r_{3T} = \frac{k_3 p_T p_E - k_{-3} p_{EBPP}}{(1 + K_{BPP} + K_{EPE} + K_{EBPEB} + K_{DEBPDEB} + K_{TPT} + K_{PPP})^2} \quad (6)$$

$$k_j = k_{oj} \exp(-E_{aj}/RT) \quad (j = 1, 2, 3, -1, -2, -3) \quad (7)$$

$$K_i = K_{oi} \exp(E_{ai}/RT) \quad (i = E, B, EB, DEB, T, P) \quad (8)$$

The reaction rate constants and the equilibrium constants are shown in Tables 1, where r is the rate law in mol/(g min), k is intrinsic rate constant, p is pressure in MPa, K is reaction equilibrium constant, E_a is reaction activation energy in J/mol, R is the gas constant, and T is temperature in Kelvin. The units of k vary depending on the form of the rate law.

Table 1: Reaction rate constants and equilibrium constants for rate laws.

Rate Constant	k_{oj}	E_{aj} J/mol	Equilibrium Constant	K_{oi}	E_{ai} J/mol
k_1	255.3	42,496	K_E	0.457	7,769
k_{-1}	5.13	68,741	K_B	6.77×10^{-3}	12,436
k_2	52.41	53,148	K_{EB}	3.19×10^{-3}	10,173
k_{-2}	2.667	73,491	K_{DEB}	8.58×10^{-4}	14,059
k_3	44.32	50,132	K_T	4.63×10^{-3}	11,768
k_{-3}	3.233	69,303	K_P	2.12×10^{-2}	8,354

References

1. Turton, R., R.C. Bailie, W. B. Whiting and J. A. Shaeiwitz, *Analysis, Synthesis and Design of Chemical Processes*, Prentice-Hall, Upper Saddle River, NJ, 1998.
2. Felder, R. M. and R. W. Rousseau, *Elementary Principles of Chemical Processes*, 2nd edition, Wiley, New York, 1986.
3. Wankat, P., *Equilibrium Staged Separation Processes*, Prentice Hall, Upper Saddle River, NJ, 1988.
4. Perry, R. H. and D. Green, eds., *Perry's Chemical Engineers' Handbook*, 7th edition, McGraw-Hill, New York, 1997.